

EELE 217 Fall 2019

Assigned Tuesday, October 29, 2019; Due at the start of class on Tuesday, November 5, 2019.

A large, rectangular lecture room has floor dimensions 25m wide x 60m long, and a floor-to-ceiling height of 20m. A raised stage fills part of the back wall, 3 meters tall and extending 15 meters into the room.

Use the following surface types to calculate *estimated* reverb time for this room using the following simplified assumptions:

- The exposed main floor area (25m x 45m) is Occupied audience, orchestra, chorus.
- The top of the stage is (15m x 25m) is Floor, wooden.
- The two side walls (2 x (60m x 20m – 3m x 15m)) and the stage front (3m x 25m) are constructed of Concrete block, smooth plaster finish.
- The ceiling is (25m x 60m) Acoustic tile on rigid surface.
- The back wall above the stage (17m x 25m) is Concrete block, painted.
- The front of the hall (25m x 20m) is Glass, heavy plate.

Your solution must include the following information *clearly circled and labeled on your solution sheet*:

(1) Create a table showing the surface area of each surface, and the absorptivity of that material at 125 Hz, 500 Hz, and 4 kHz (see the attached material information table).

(2) Calculate the total absorption for the room at each of the three frequencies by summing the product of the surface area and the absorptivity for all surfaces.

(3) Calculate the estimated Sabine reverberation time (T_{60}) at 125 Hz, 500 Hz, and 4 kHz.

$$T_{60} = \frac{0.161V}{\sum_i S_i a_i}$$

V = total volume in m^3

S_i = area of surface i in m^2

a_i = absorptivity of surface i

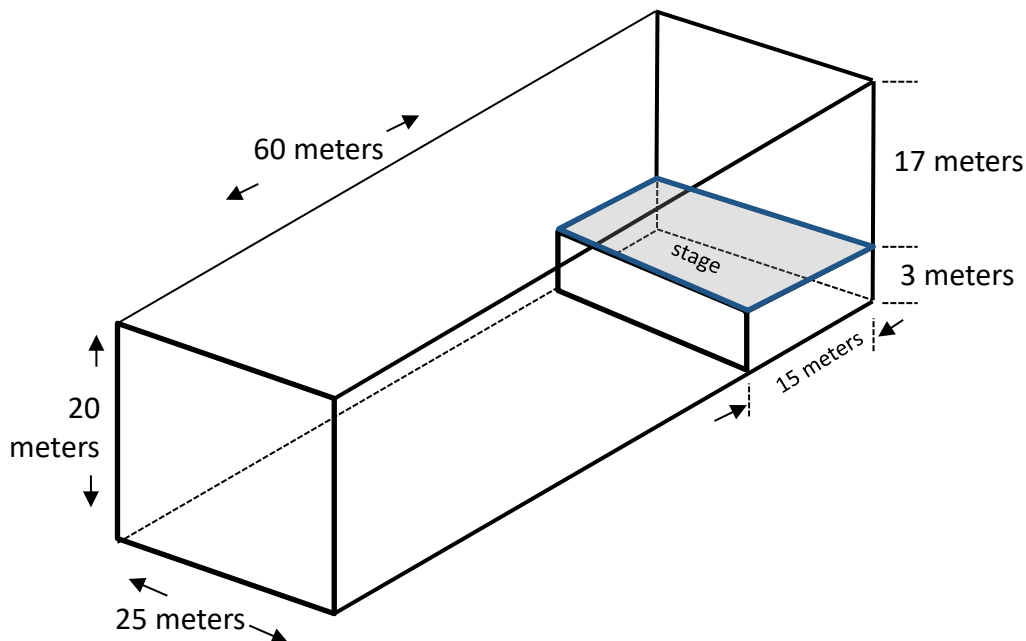

Be careful to calculate the volume of the room *subtracting* the volume (3x15x25) occupied by the stage. Similarly, be careful to calculate the wall surface areas taking into account that the stage sides and back *cover* part of the side and back wall surfaces.

Table 12.5.1 Representative Sabine absorptivities and absorptions

Sabine Absorptivity a

Description	Frequency in Hz					
	125	250	500	1000	2000	4000
Occupied audience, orchestra, chorus	0.40	0.55	0.80	0.95	0.90	0.85
Upholstered seats, cloth-covered, perforated bottoms	0.20	0.35	0.55	0.65	0.60	0.60
Upholstered seats, leather-covered	0.15	0.25	0.35	0.40	0.35	0.35
Carpet, heavy on undercarpet (1.35 kg/m ² felt or foam rubber)	0.08	0.25	0.55	0.70	0.70	0.75
Carpet, heavy on concrete	0.02	0.06	0.14	0.35	0.60	0.65
Acoustic plaster (approximate)	0.07	0.17	0.40	0.55	0.65	0.65
Acoustic tile on rigid surface	0.10	0.25	0.55	0.65	0.65	0.60
Acoustic tile, suspended (false ceiling)	0.40	0.50	0.60	0.75	0.70	0.60
Curtains, 0.48 kg/m ² velour, draped to half area	0.07	0.30	0.50	0.75	0.70	0.60
Wooden platform with airspace	0.40	0.30	0.20	0.17	0.15	0.10
Wood paneling, 3/8-1/2 in. over 2-4 in. air space	0.30	0.25	0.20	0.17	0.15	0.10
Plywood, 1/4 in. on studs, fiberglass backing	0.60	0.30	0.10	0.09	0.09	0.09
Wooden walls, 2 in.	0.14	0.10	0.07	0.05	0.05	0.05
Floor, wooden	0.15	0.11	0.10	0.07	0.06	0.07
Floor, linoleum, flexible tile, on concrete	0.02	0.03	0.03	0.03	0.03	0.02
Floor, linoleum, flexible tile, on subfloor	0.02	0.04	0.05	0.05	0.10	0.05
Floor, terrazzo	0.01	0.01	0.02	0.02	0.02	0.02
Concrete (poured, unpainted)	0.01	0.01	0.02	0.02	0.02	0.02
Gypsum, 1/2 in. on studs	0.30	0.10	0.05	0.04	0.07	0.09
Plaster, smooth on lath	0.14	0.10	0.06	0.04	0.04	0.03
Plaster, smooth on lath on studs	0.30	0.15	0.10	0.05	0.04	0.05
Plaster, 1 in. damped on concrete block, brick, lath	0.14	0.10	0.07	0.05	0.05	0.05
Glass, heavy plate	0.18	0.06	0.04	0.03	0.02	0.02
Glass, windowpane	0.35	0.25	0.18	0.12	0.07	0.04
Brick, unglazed, no paint	0.03	0.03	0.03	0.04	0.05	0.07
Brick, smooth plaster finish	0.01	0.02	0.02	0.03	0.04	0.05
Concrete block, no paint	0.35	0.45	0.30	0.30	0.40	0.25
Concrete block, painted	0.10	0.05	0.06	0.07	0.09	0.08
Concrete block, smooth plaster finish	0.12	0.09	0.07	0.05	0.05	0.04
Concrete block, slotted two-well	0.10	0.90	0.50	0.45	0.45	0.40
Perforated panel over isolation blanket, 10% open area	0.20	0.90	0.90	0.90	0.85	0.85
Fiberglass, 1 in. on rigid backing	0.08	0.25	0.45	0.75	0.75	0.65
Fiberglass, 2 in. on rigid backing	0.21	0.50	0.75	0.90	0.85	0.80
Fiberglass, 2 in. on rigid backing, 1 in. airspace	0.35	0.65	0.80	0.90	0.85	0.80
Fiberglass, 4 in. on rigid backing	0.45	0.90	0.95	1.00	0.95	0.85

Sound Absorption A in m²

Single person or heavily upholstered seat	0.40	0.70	0.85	0.95	0.90	0.80
Wooden chair, table, furnishing, for one person	0.02	0.03	0.05	0.08	0.08	0.05